

Overview

The rechargeable batteries are lead-lead dioxide systems. The dilute sulfuric acid electrolyte is absorbed by separators and plates and thus immobilized. Should the battery be accidentally overcharged producing hydrogen and oxygen, special oneway valves allow the gases to escape thus avoiding excessive pressure build-up. Otherwise, the battery is completely sealed and is, therefore, maintenance-free, leak proof and usable in any position.

Battery Construction

Component	Positive plate	Negative plate	Container	Cover	Safety valve	Terminal	Separator	Electrolyte
Raw material	Lead dioxide	Lead	ABS	ABS	Rubber	Copper	Fiberglass	Sulfuric acid

General Features

- Absorbent Glass Mat (AGM) technology for efficient gas recombination of up to 99% and freedom from electrolyte maintenance or water adding.
- Not restricted for air transport-complies with IATA/ICAO Special Provision A67.
- UL-recognized component.
- Can be mounted in any orientation.
- Computer designed lead, calcium tin alloy grid for high power density.
- Long service life, float or cyclic applications.
- Maintenance-free operation.
- Low self discharge.
- Case and cover available in both standard and flame retardant ABS.

Dimensions and Weight

Length(mm / inch)	546 / 21.5
Width(mm / inch)	125 / 4.92
Height(mm / inch)	317 / 12.5
Total Height(mm / inch)	323 / 12.7
Approx. Weight(Kg / lbs)	58.5 / 129.1

* Weight deviation: ± 3%

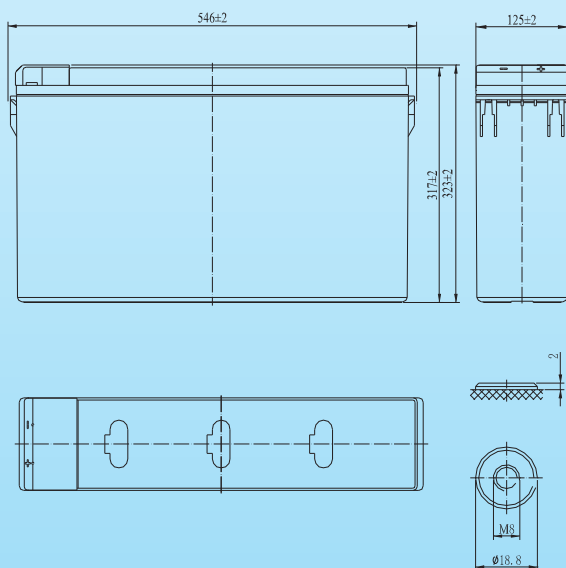

Battery Specification

Performance Characteristics	
Nominal Voltage	12V
Number of cell	6
Design Life	10years
Nominal Capacity 77°F(25°C)	
10 hour rate (18.0A, 10.8V)	180Ah
5 hour rate (32.3A, 10.5V)	161.5Ah
1 hour rate (118A, 9.6V)	118Ah
Internal Resistance	
Fully Charged battery 77°F(25°C)	≤4.0mOhms
Self-Discharge	
3% of capacity declined per month at 20°C(average)	
Operating Temperature Range	
Discharge	-20~60°C
Charge	-10~60°C
Storage	-20~60°C
Max. Discharge Current 77°F(25°C)	
1000A(5s)	
Short Circuit Current	2700A
Charge Methods: Constant Voltage Charge77°F(25°C)	
Cycle use	2.40-2.45VPC
Maximum charging current	54A
Temperature compensation	-30mV/°C
Standby use	2.23-2.27VPC
Temperature compensation	-20mV/°C

Discharge Constant Current (Amperes at 77°F25°C)

End Point Volts/Cell	Time							
	10min	15min	30min	45min	1h	3h	5h	10h
1.60V	355	300	197	145	118	51.0	33.0	18.4
1.65V	332	285	192	143	116	50.3	32.8	18.3
1.70V	308	269	187	140	114	49.5	32.6	18.2
1.75V	285	254	181	138	111	48.8	32.3	18.1
1.80V	261	238	176	135	109	48.0	32.1	18.0

Discharge Constant Power (Watts at 77°F25°C)

End Point Volts/Cell	Time							
	10min	15min	30min	45min	1h	2h	3h	5h
1.60V	590	525	360	274	225	134	98.0	64.1
1.65V	566	503	349	268	221	132	97.0	63.6
1.70V	541	480	339	262	217	130	96.0	63.1
1.75V	517	458	328	257	212	127	95.0	62.5
1.80V	492	435	318	251	208	125	94.0	62.0

(Note)The above characteristics data are average values obtained within three charge/discharge cycles not the minimum values.All data shall be changed without notice, Vision reserves the right to explain and update the information contained hereinto.



VISION GROUP
Shenzhen Center Power
Tech.Co.Ltd.,

CT12-180X

12V1 80Ah(10hr)

