

## Overview

The rechargeable batteries are lead-lead dioxide systems. The dilute sulfuric acid electrolyte is absorbed by separators and plates and thus immobilized. Should the battery be accidentally overcharged producing hydrogen and oxygen, special oneway valves allow the gases to escape thus avoiding excessive pressure build-up. Otherwise, the battery is completely sealed and is, therefore, maintenance-free, leak proof and usable in any position.



## Battery Construction

|              |                |                |           |       |              |          |            |               |
|--------------|----------------|----------------|-----------|-------|--------------|----------|------------|---------------|
| Component    | Positive plate | Negative plate | Container | Cover | Safety valve | Terminal | Separator  | Electrolyte   |
| Raw material | Lead dioxide   | Lead           | ABS       | ABS   | Rubber       | Copper   | Fiberglass | Sulfuric acid |

## General Features

- Absorbent Glass Mat (AGM) technology for efficient gas recombination of up to 99% and freedom from electrolyte maintenance or water adding.
- Not restricted for air transport-complies with IATA/ICAO Special Provision A67.
- UL-recognized component.
- Can be mounted in any orientation.
- Computer designed lead, calcium tin alloy grid for high power density.
- Long service life, float or cyclic applications.
- Maintenance-free operation.
- Low self discharge.
- Case and cover available in both standard and flame retardant ABS.

## Dimensions and Weight

|                          |             |
|--------------------------|-------------|
| Length(mm / inch)        | 134 / 5.27  |
| Width(mm / inch)         | 34 / 1.34   |
| Height(mm / inch)        | 61 / 2.40   |
| Total Height(mm / inch)  | 67 / 2.64   |
| Approx. Weight(Kg / lbs) | 0.65 / 1.43 |

\* Weight deviation:  $\pm 5\%$

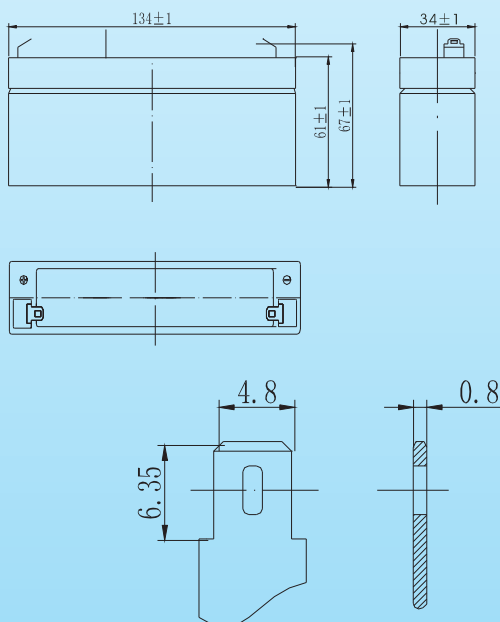

## Battery Specification

### Performance Characteristics

|  |                       |
|--|-----------------------|
| Nominal Voltage                                    | 6V                    |
| Number of cell                                     | 3                     |
| Design Life  | 5 years               |
| Nominal Capacity 77°F(25°C)                        |                       |
| 20 hour rate (0.16A, 5.25V)                        | 3.2Ah                 |
| 10 hour rate (0.31A, 5.25V)                        | 3.1Ah                 |
| 5 hour rate (0.57A, 5.25V)                         | 2.85Ah                |
| 1 hour rate (2.10A, 4.8V)                          | 2.10Ah                |
| Internal Resistance                                |                       |
| Fully Charged battery 77°F(25°C)                   | $\leq 30\text{mOhms}$ |
| Self-Discharge                                     |                       |
| 3% of capacity declined per month at 20°C(average) |                       |
| Operating Temperature Range                        |                       |
| Discharge  | -20~60°C              |
| Charge   | -10~60°C              |
| Storage  | -20~60°C              |
| Max. Discharge Current 77°F(25°C)                  | 48A(5s)               |
| Short Circuit Current                              | 160A                  |

### Discharge Constant Current (Amperes at 77°F25°C)

| End Point  |      |       |       |       |      |      |      |      |      |  |
|------------|------|-------|-------|-------|------|------|------|------|------|--|
| Volts/Cell | 5min | 10min | 15min | 30min | 1h   | 3h   | 5h   | 10h  | 20h  |  |
| 1.60V      | 13.0 | 8.80  | 6.10  | 3.70  | 2.10 | 0.89 | 0.62 | 0.33 | 0.17 |  |
| 1.65V      | 12.3 | 8.38  | 5.83  | 3.55  | 2.02 | 0.86 | 0.60 | 0.32 | 0.16 |  |
| 1.70V      | 11.6 | 7.94  | 5.55  | 3.40  | 1.94 | 0.83 | 0.59 | 0.32 | 0.16 |  |
| 1.75V      | 10.9 | 7.50  | 5.26  | 3.23  | 1.86 | 0.80 | 0.57 | 0.31 | 0.16 |  |
| 1.80V      | 10.2 | 7.05  | 4.97  | 3.06  | 1.77 | 0.76 | 0.55 | 0.30 | 0.16 |  |

### Discharge Constant Power (Watts at 77°F25°C)

| End Point  |      |       |       |       |       |      |      |      |      |  |
|------------|------|-------|-------|-------|-------|------|------|------|------|--|
| Volts/Cell | 5min | 10min | 15min | 30min | 45min | 1h   | 2h   | 3h   | 5h   |  |
| 1.60V      | 23.0 | 15.3  | 11.80 | 7.17  | 5.33  | 4.10 | 2.42 | 1.81 | 1.24 |  |
| 1.65V      | 21.6 | 14.4  | 11.20 | 6.81  | 5.09  | 3.93 | 2.35 | 1.77 | 1.22 |  |
| 1.70V      | 20.2 | 13.6  | 10.60 | 6.44  | 4.83  | 3.75 | 2.27 | 1.72 | 1.19 |  |
| 1.75V      | 18.7 | 12.7  | 9.89  | 6.07  | 4.57  | 3.56 | 2.18 | 1.67 | 1.17 |  |
| 1.80V      | 17.4 | 11.8  | 9.24  | 5.69  | 4.31  | 3.37 | 2.08 | 1.61 | 1.14 |  |

(Note)The above characteristics data are average values obtained within three charge/discharge cycles not the minimum values.All data shall be changed without notice, Vision reserves the right to explain and update the information contained hereinto.

