

GFX-300 2V300Ah

The blue transparent case is made of AS imported from Italy. It is resistant to corrosion, retardant to flame, strong and has a nice appearance. The internal structure and status of battery can be observed outside through the transparent case. With the combined application of porous rubber and porous PVC, the separator has a high porosity and good corrosion-resistance, therefore it can absorb more acid to effectively prevent internal short-circuit, and the diffusion of electrolyte is fast to reduce greatly the resistance of battery ensuring sufficient electrolyte when of discharge.

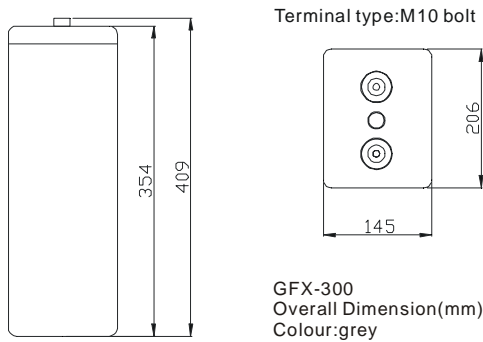

Dimensions and Weight



Specifications

Nominal voltage	2V	
Rated capacity (10 hour rate)	300Ah	
Dimension	Length (L)	145mm
	Width (W)	206mm
	Heigh (h)	354mm
	Total height	409mm
Approx. mass (without electrolyte)	19.2Kg	
Approx. mass (with electrolyte)	24.3Kg	

Basic electric performance parameters

	cut-off voltage (V)	Capacit (Ah)
1 hour rate	1.67	159
3 hour rate	1.75	225
5 hour rate	1.77	258
10 hour rate	1.80	300
24 hour rate	1.85	375
48 hour rate	1.85	402
72 hour rate	1.85	420
96 hour rate	1.85	420
120 hour rate	1.85	425
240 hour rate	1.85	430

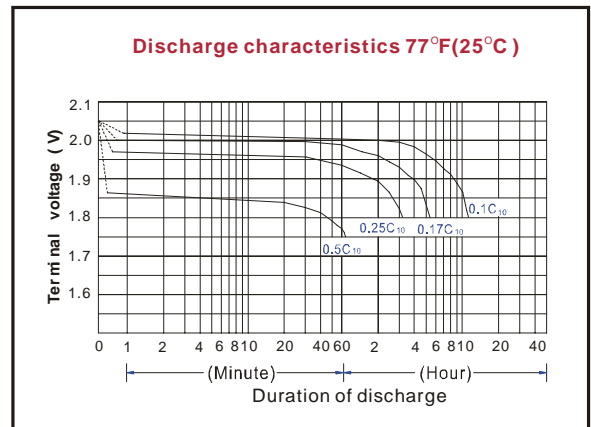
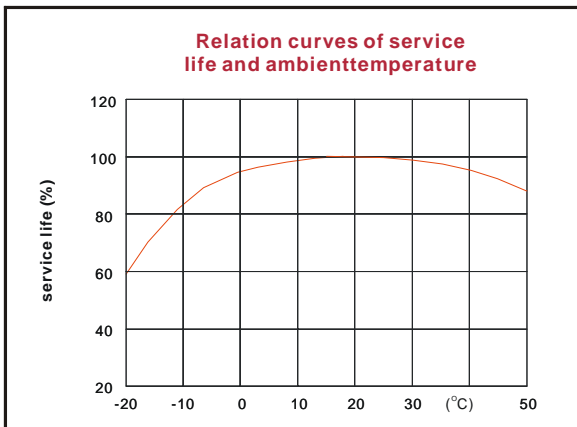
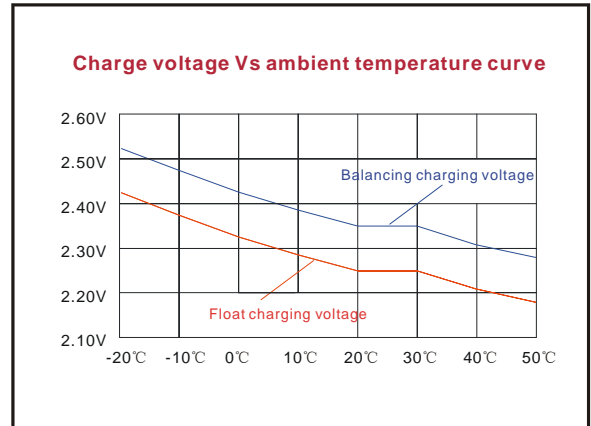
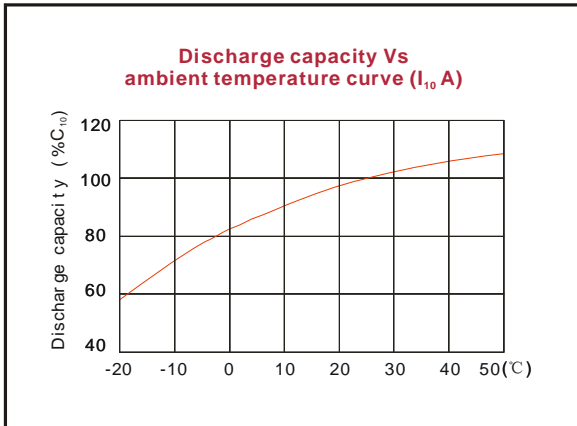

This information is generally descriptive only and is not intended to make or imply any representation, guarantee or warranty with respect to any cells and batteries. Cell and battery designs/specifications are subject to modification without notice. Contact Shenzhen Center Power Tech. Co., Ltd for the latest information.

Shenzhen Center Power Tech. Co., Ltd.
 Center Power Industrial Park, Tongfu Industrial District Dapeng Town,
 518120 Shenzhen, China
 Tel: +86-755-8431 8088 Fax: +86-755-8431 8038
 Email: sales@vision-batt.com

