

## GFMJ-600 2V600Ah

The battery electrolyte contains fumed silica and there is no flow, no leakage or no gradation of acid liquor, the battery slot and cover is made of ABS materials through hot seal. There is no risk of leakage during the utilization and transportation, and it is safe and reliable. The gel electrolyte is in dilute sol state when being injected. Excessive electrolyte can fill in all the space inside battery. Under circumstance of high-temperature and overcharge, the battery will not dry out, the gel battery has large heat capacity and good radiation performance. It is not easy to appear thermal runaway. The battery can work under severe environment.

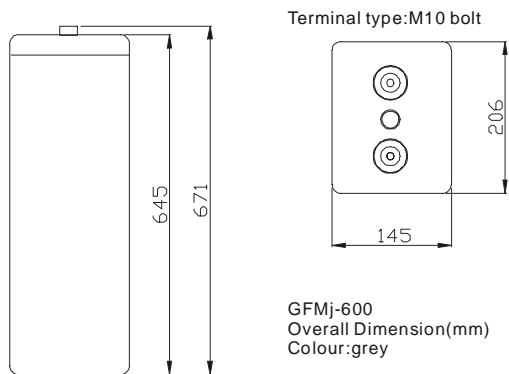

### Dimensions and Weight



### Specifications

Nominal voltage	2V	
Rated capacity (10 hour rate)	600Ah	
Dimension	Length	145mm
	Width	206mm
	Heigh	645mm
	Total	671mm
Approx. mass	50Kg	

### Main technical parameters And Environment requirements

Environment temperature	-20℃~50℃
Environmental temperature for best utilization	25℃±5℃
Float charging voltage	2.25V/unit
Balancing charging voltage	2.35V/unit
Temperature adjustment coefficient	-3mV/℃/unit
Max charging current	0.20C <sub>10</sub> A
Design service life	20 years(25℃)
Floating service life	12~14 years(25℃)
Self-discharge rate	Less than 40% after 2-year storage at 20℃
Recover performance after deep discharge	The battery can be recharged to 95% of the rated capacity after 12-hour deep discharge

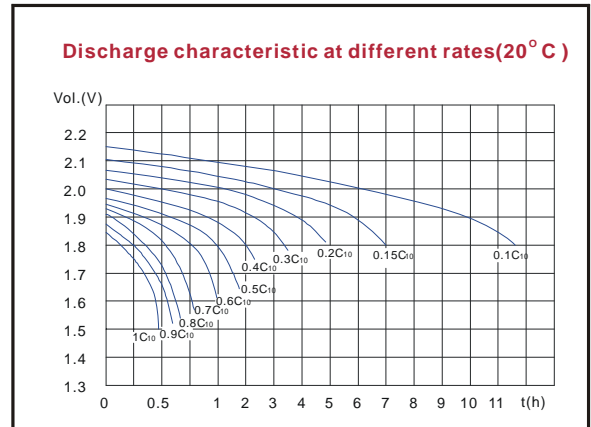
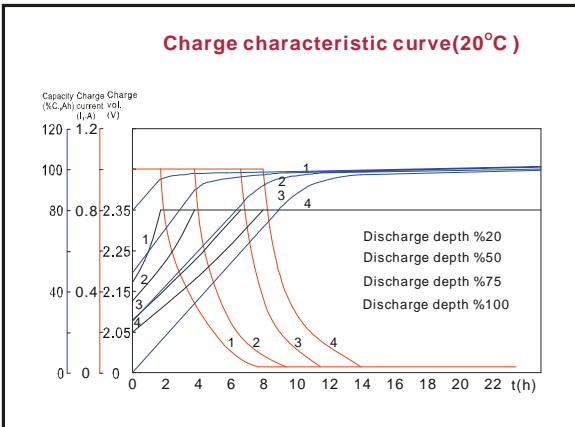
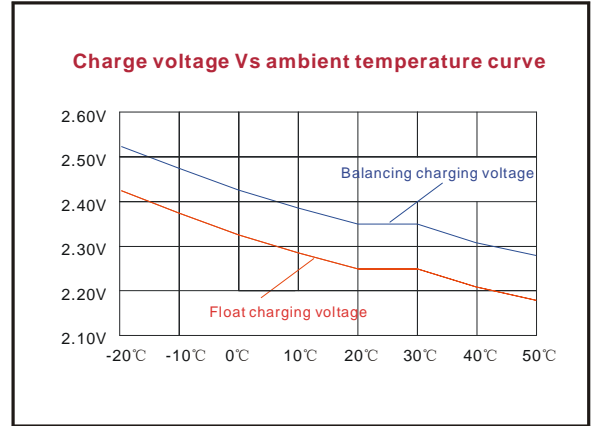
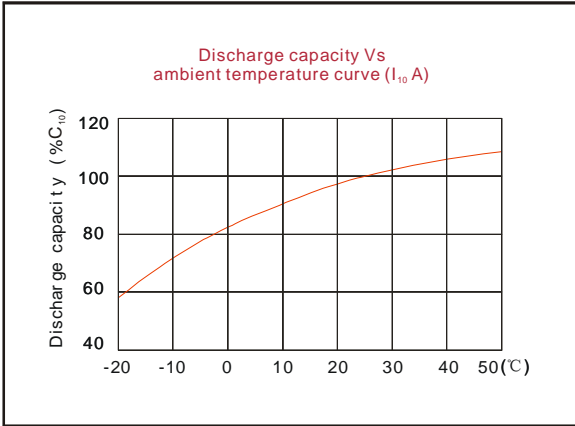

This information is generally descriptive only and is not intended to make or imply any representation, guarantee or warranty with respect to any cells and batteries. Cell and battery designs/specifications are subject to modification without notice. Contact Shenzhen Center Power Tech. Co., Ltd for the latest information.

**Shenzhen Center Power Tech. Co., Ltd.**  
 Center Power Industrial Park, Tongfu Industrial District Dapeng Town,  
 518120 Shenzhen, China  
 Tel: +86-755-8431 8088 Fax: +86-755-8431 8038  
 Email: sales@vision-batt.com

